

THESIS PROPOSAL

Aubert Ndjolba | Structural Option

PENN COLLEGE OF TECHNOLOGY

Faculty advisor: Dr. Boothby

Date: 01/13/12



Table of Contents:

| | |
|--|----|
| Executive Summary..... | 3 |
| Building Introduction..... | 4 |
| Existing System Structural Overview..... | 5 |
| ✚ Foundation..... | 5 |
| ✚ Floor Systems..... | 8 |
| ✚ Framing System..... | 9 |
| ✚ Lateral System..... | 11 |
| ✚ Roof System..... | 15 |
| Design Codes..... | 16 |
| Problem Statement..... | 17 |
| Proposed Solution..... | 17 |
| Breath Topics..... | 19 |
| ✚ Construction..... | 19 |
| ✚ Architectural..... | 19 |
| Methods..... | 19 |
| Tasks..... | 20 |
| Timetable..... | 21 |
| Conclusion..... | 22 |

EXECUTIVE SUMMARY

Located in Williamsport, Pennsylvania, The Dauphin Hall (DH) is 70 feet high, 196 feet wide and 362 feet long. This 4 story student housing, completed in August, 2010, has a gravity system consisting of lightweight concrete on metal deck and non load-bearing Concrete Masonry Unit (CMU) walls. The metal deck rests on k-series steel joists. The lateral resisting system of the DH consists of moment frames in both the East-West and North-South direction.

The focus of this report is to alter the lateral resisting systems of the DH. The proposed lateral system will utilize reinforced load bearing CMU walls with precast hollow core planks as the floor system. Once the best configuration is determined, wind and seismic forces will be calculated; and frame stiffness, lateral movement, and both the direct and torsional shear will be analyzed.

In addition to this structural depth, two non-structural breadths will be undertaken. A cost and schedule analysis will be used to compare the effect of the alternate lateral system to the original design in terms of time and economy. Also, an architectural breadth will be undertaken to investigate the effects of continuous load-bearing CMU's from the first floor to the roof on the floor plan. The room layouts will have to be readjusted appropriately and the façade may be redesign if necessary.

To complete the above tasks, a four milestone schedule was created to ensure work will be completed by the deadline.

BUILDING INTRODUCTION

The Pennsylvania College of Technology is located in the 200 block of Rose Street in Williamsport, PA. Dauphin Hall, the newest dormitory on campus, was constructed in August 2010. It was a result of the collaboration between Murray Associates Architects, P.C; IMC as the general contractor; Woodburn & Associates, INC as the food service designer; Whitney, Bailey, Cox & Magnani, LLC as the civil engineering firm; and Gatter & Diehl, INC as the MEP firm. This new structure costs approximately \$ 26,000,000 and was delivered using the design-bid-build project delivery method.



At approximately 123,676 GSF, this latest addition to the student housing, provides 268 students with suites and single rooms. A 40-50 student seating commons enclosed with glass provides a social space for student collaboration. Located within the dormitory are other amenities such as: a 460 seat dining room, two private dining rooms for faculties, a 40 station satellite fitness center, two large leisure rooms, a student grocery store, laundry facilities, student mail boxes, Resident Life Offices, campus police office, and a Hall Coordinator apartment.



Figure 2: South facade



Figure 3: South facade

STRUCTURAL OVERVIEW

The structure of the DH is a combination of shallow foundation and stone piers, and composite steel decking with steel framing. The exterior and interior walls are composed primarily of brick and non-load bearing concrete masonry units.

FOUNDATIONS

CMT Laboratories, Inc, performed several test borings of the DH. According to the geotechnical engineers' analysis for this site, they have determined that the site was filled with brown silty clay, and brown silty sand with gravel. Furthermore, it was found that the cohesive alluvial soils beneath the fill materials have low shear strength.

In light of these conditions, the conventional spread/column and continuous footing foundations will not provide adequate bearing capacity to support the building. Deep foundations such as concrete filled tapered piles could support the structure but are not the most economical approach. Therefore, a practical solution is subsurface improvement with the use of shallow foundation.

The final decision was to use stone piers which were considered the most technically sound and economically feasible method. Those stone piers are typically eighteen (18) to thirty-six (36) inches in diameter depending on their loading and settlement criteria.

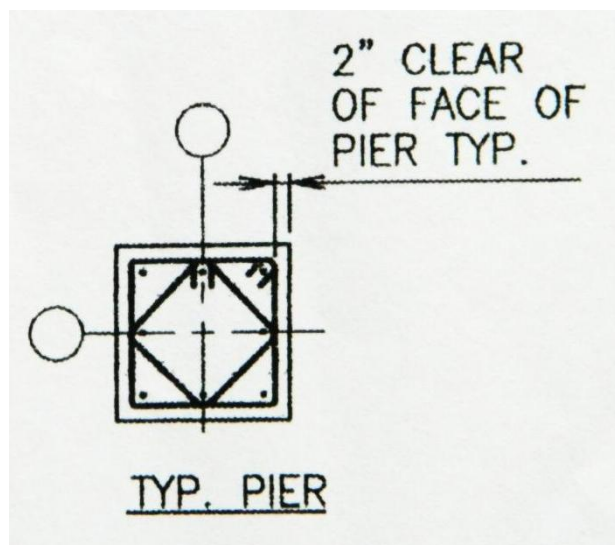

Figure 4: Typical Pier Detail

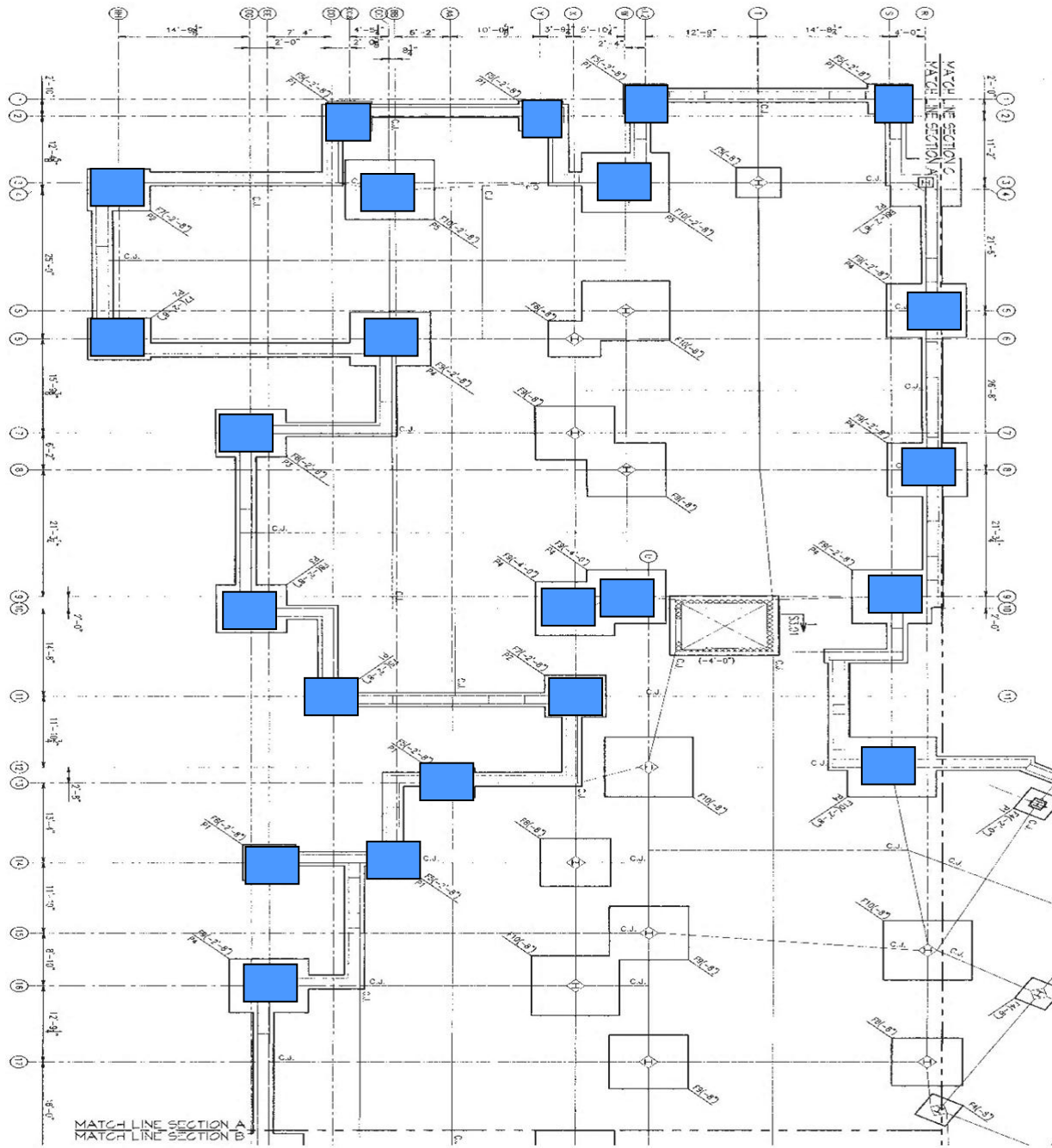

Figure 5: Stone Pier locations



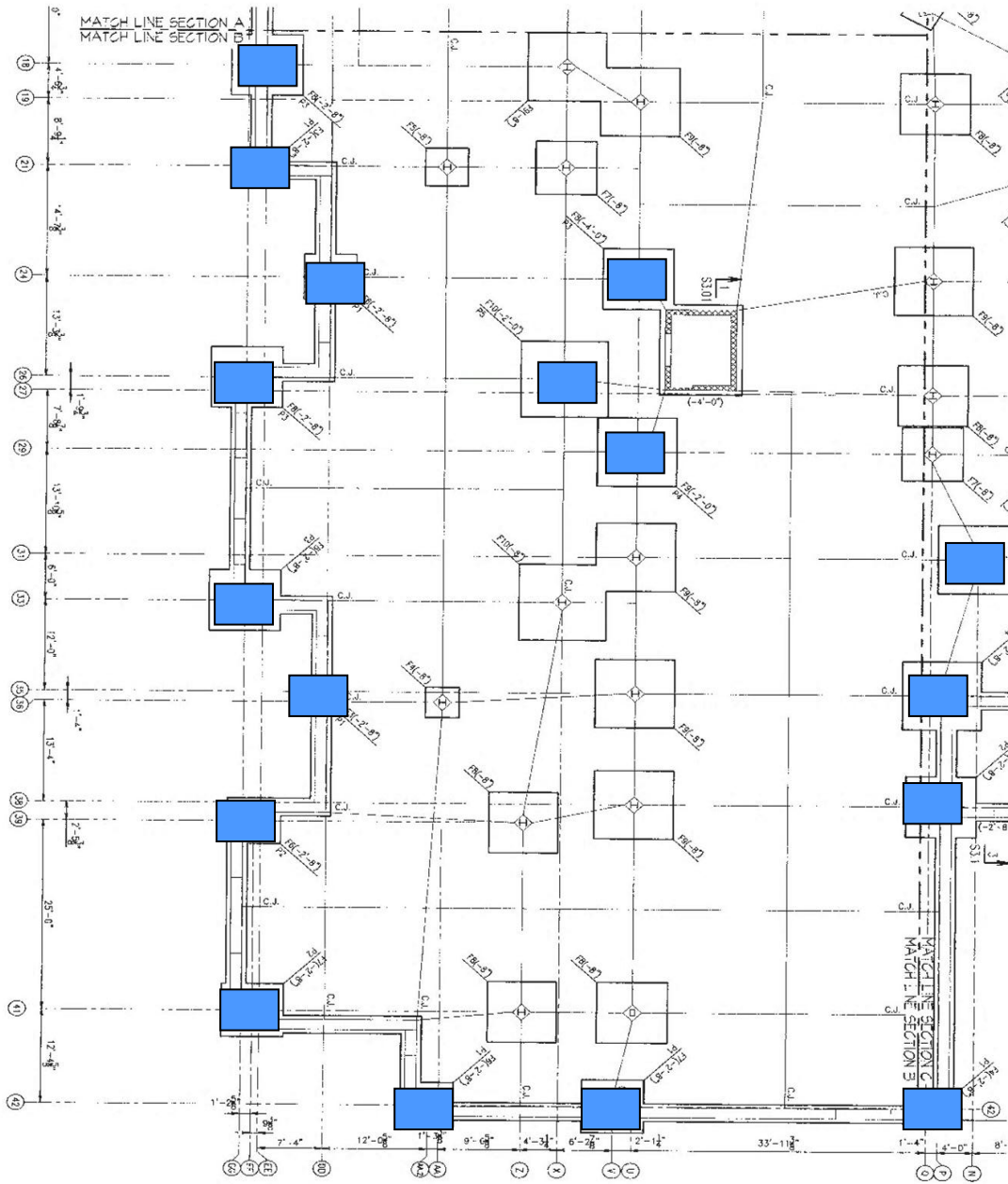

Figure 6: Stone Pier locations



FLOOR SYSTEMS

The floor system of the DH is composed of 4" Light weight concrete slab, reinforced with 6"×6" -W2.9×W2.9 welded wire mesh, on 1 ½" - 20 gage Vulcraft composite deck. The joists supporting the floor system are spaced equally in column bays with a maximum spacing of 2'-0" O.C in areas of floor framing.

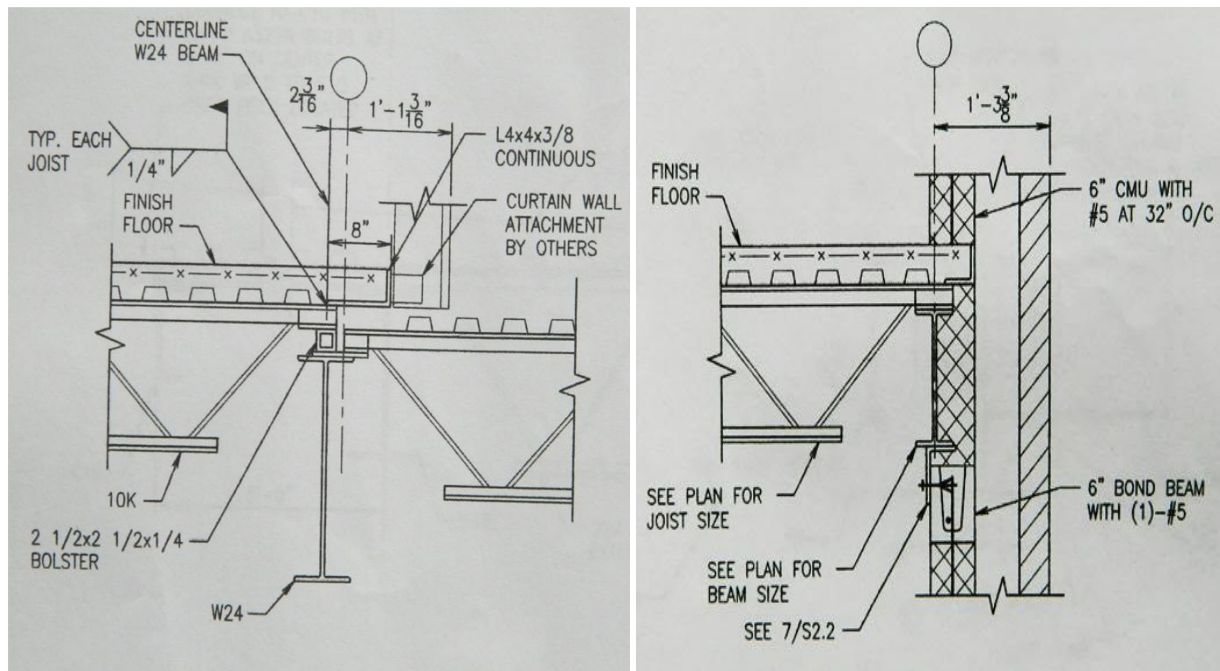

Figure 7: Typical Floor Section showing beam and columns relationship

FRAMING SYSTEM

The superstructure of the DH is primarily a combination of K-series joists, W24 girders, steel columns raging in size from W8's to W10's, and light gage metal framing. The K-series joists are spaced 2'-0" on O.C. The columns are typically on a 25'x30' grid and encased by 5/8" Gypsum board or 6" painted CMU. HSS columns were used in locations near the stairwells. Interior partitions consist of non load-bearing Concrete Masonry Units (CMU).

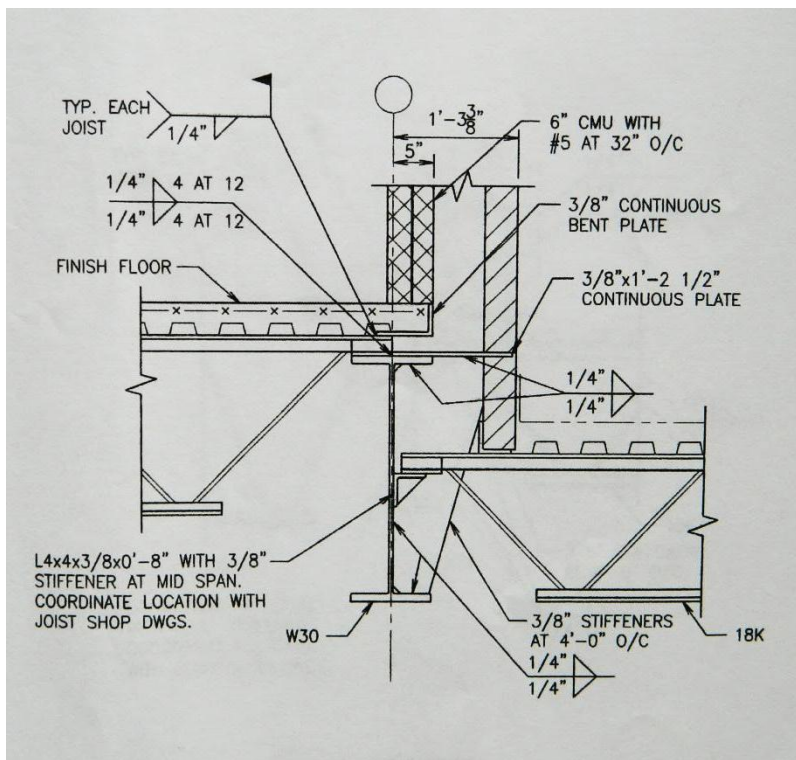

Figure 8: Joists and beam interaction

LATERAL SYSTEM

The lateral resisting system in the DH consists of steel moment connections in both the East-West direction and the North-South direction. The lateral force resisting connections can be seen in figure 10 below.

The building façade collects wind forces that are then transferred to the respective floor diaphragm. These forces are transmitted through the diaphragm until the moment connections are engaged. The remainder of the technical report will discuss the lateral system in more detail.

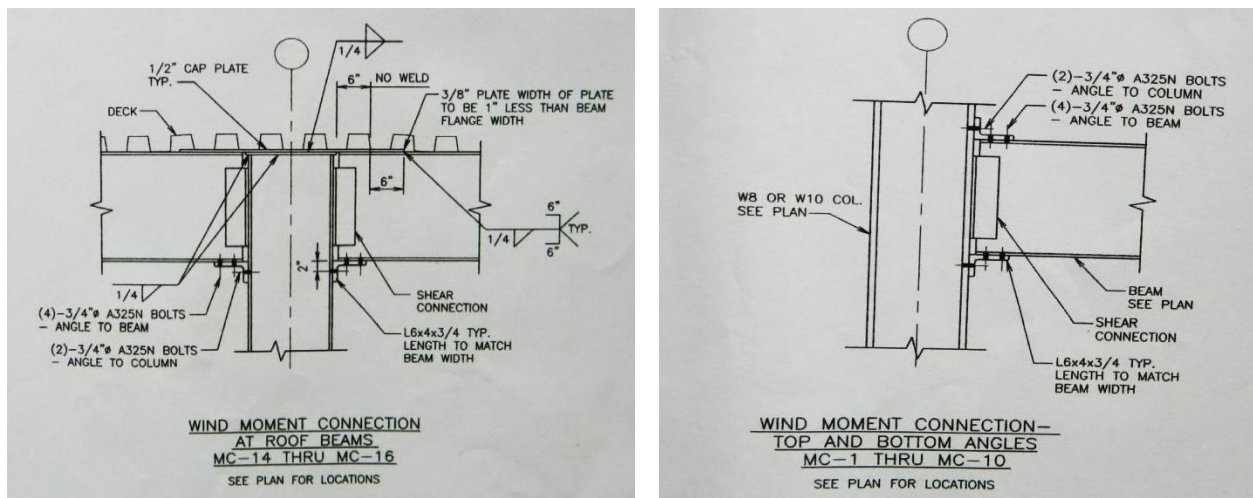

Figure 10: Moment Connections

Aubert Ndjolba | Structural option

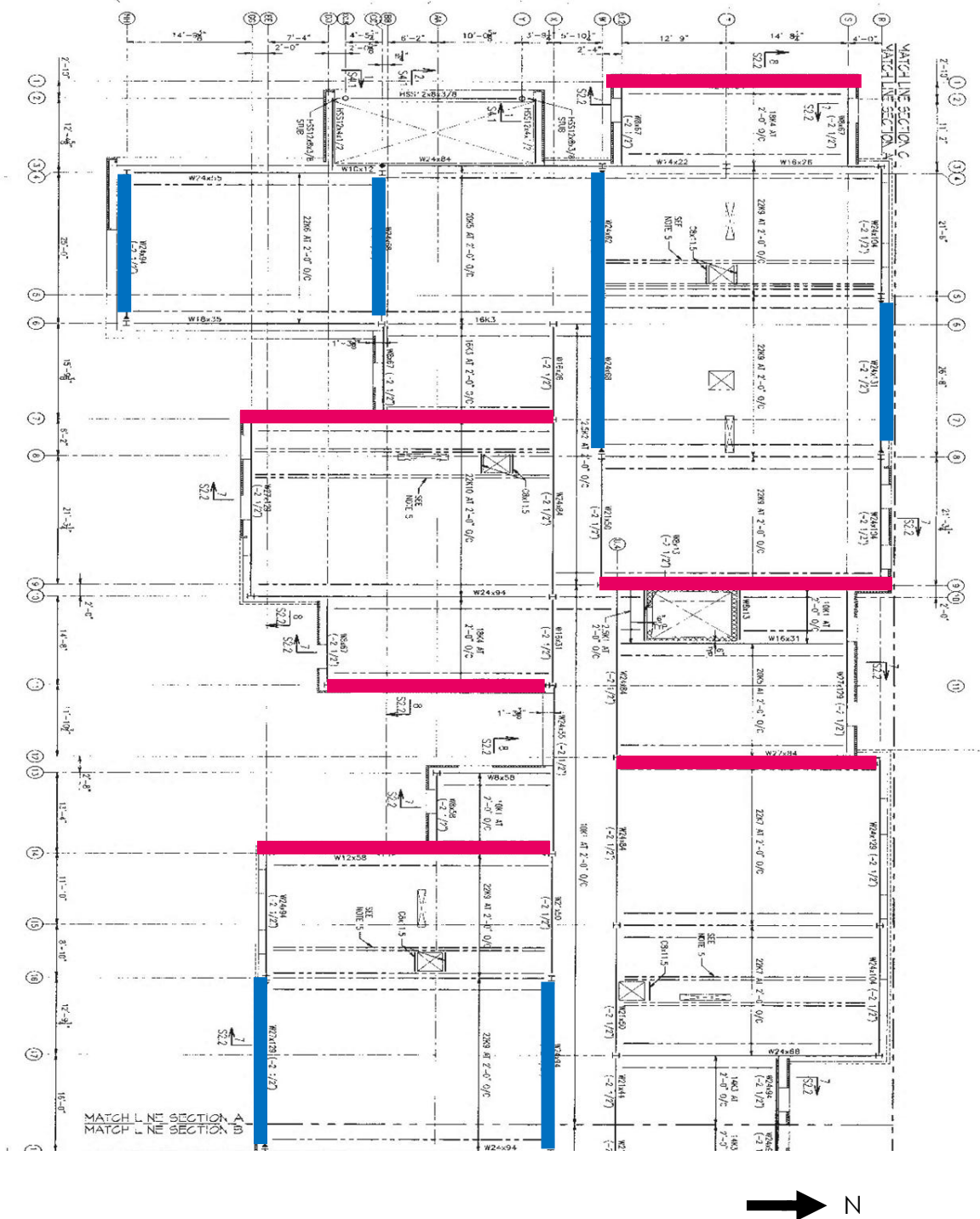

Figure 11: Moment Frames with Moment Connections at the End of the Members. (West End)

ROOF SYSTEMS

There is only one roof system on the DH dormitory. It consists of 1 1/2" – 20 gage type B roof deck. The roof deck is then supported by joists spaced at a maximum distance of 4'-0" O.C. between the column bays.

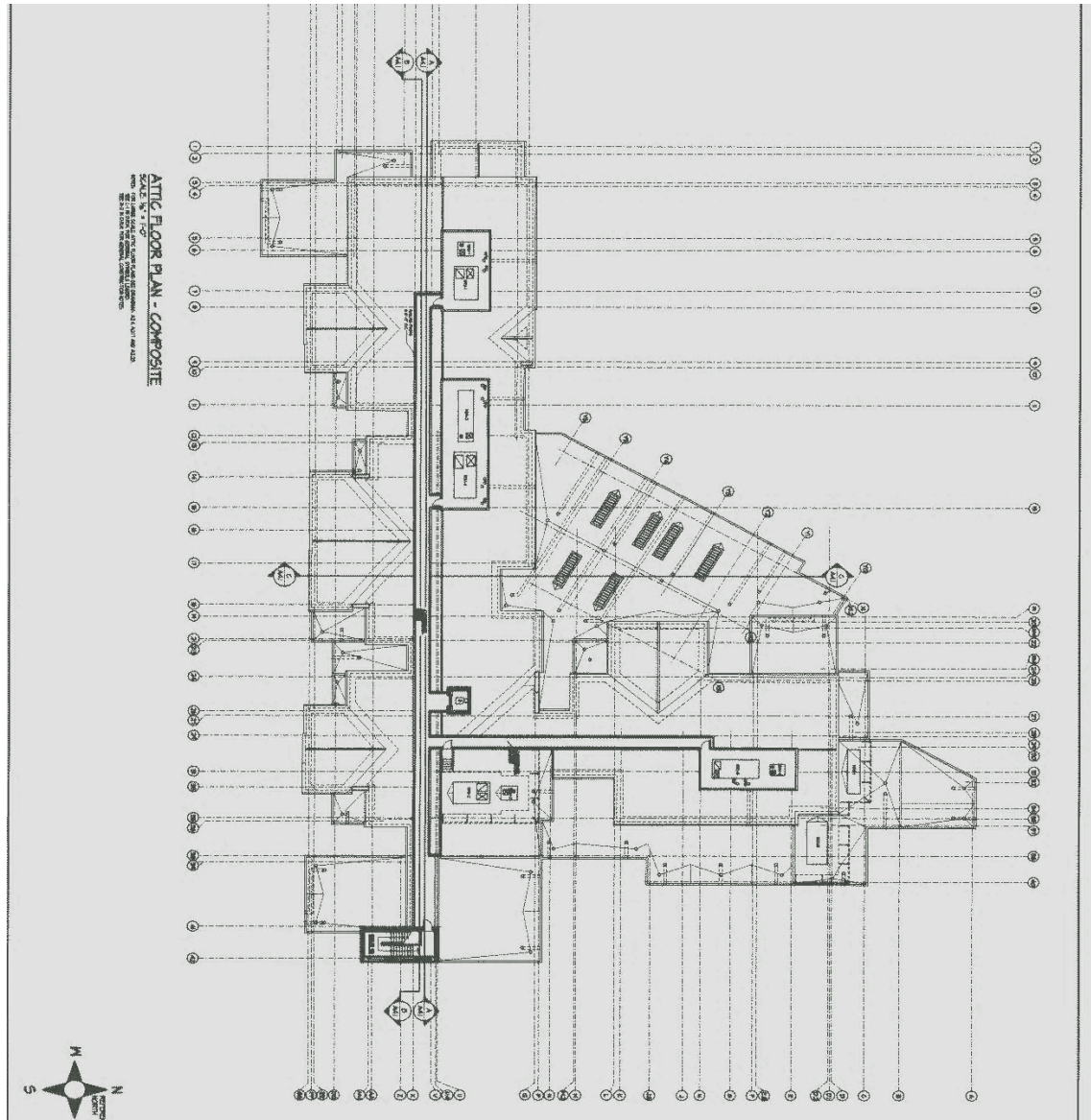

Figure 14: Roof plans

DESIGN CODES

All equipment and components of the DH are designed to comply with all applicable latest editions of articles and sections of the following codes in compliances with all Federal, State, County, and Local ordinances and regulations:

- ✚ 2006 International Building Code (IBC)
- ✚ National Electrical Code (NEC),
- ✚ Uniform Plumbing Code (UPC),
- ✚ National Sanitation Foundation (NSF)
- ✚ Specifications for structural concrete for buildings (ACI 301)
- ✚ Building Code Requirements for Reinforced Concrete (ACI 318-08)
- ✚ Recommended Practice for Hot Weather Concreting (ACI 305R)
- ✚ Recommended Practice for Cold Weather Concreting (ACI 306R)
- ✚ Recommended Practice for Concrete Formwork (ACI 347)
- ✚ American Society of Civil Engineers (ASCE 7- 10)

PROBLEM STATEMENT

In technical Report 1 and 3, the gravity and lateral resisting system of the DH were analyzed and it was found that both systems are adequate in both strength and serviceability. However, the existing lateral system described above is composed of complicated moment connections that are time consuming and labor intensive. An example of this type of connection can be seen in the figure 15 below, where a combination of welds and bolts are being used. This presents an opportunity for an alternative design of the lateral system.

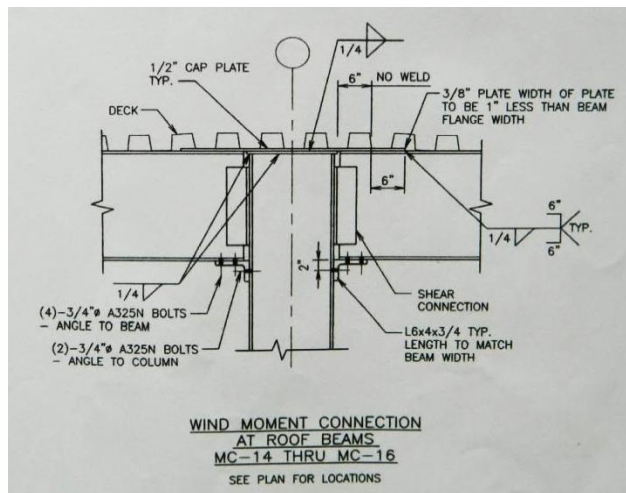

Figure 15: Wind moment Connection

PROPOSED SOLUTION

The purpose of this thesis investigation will be to redesign the lateral system of the DH. Two alternate lateral systems could be considered here:

Option I:

Option I will maintain the current floor system and design but utilize shear walls to resist lateral forces in both directions. Due to the size of the building, the shear walls will be inserted in areas around the end stairwells and core elevators. Then the system will be analyzed and the shear walls will be checked to ensure the stability of the building. Wind loads, seismic loads, and torsional effects will be computed.

Option II:

Option II will consist primarily of a combination of Concrete Masonry Units (CMU) load-bearing wall and non load-bearing walls. All reinforced CMU load-bearing walls will be continuous from the first floor to the roof in both transverse and longitudinal direction. The floor system will be composed of hollow core precast concrete planks. The figure below shows how the system will be composed.

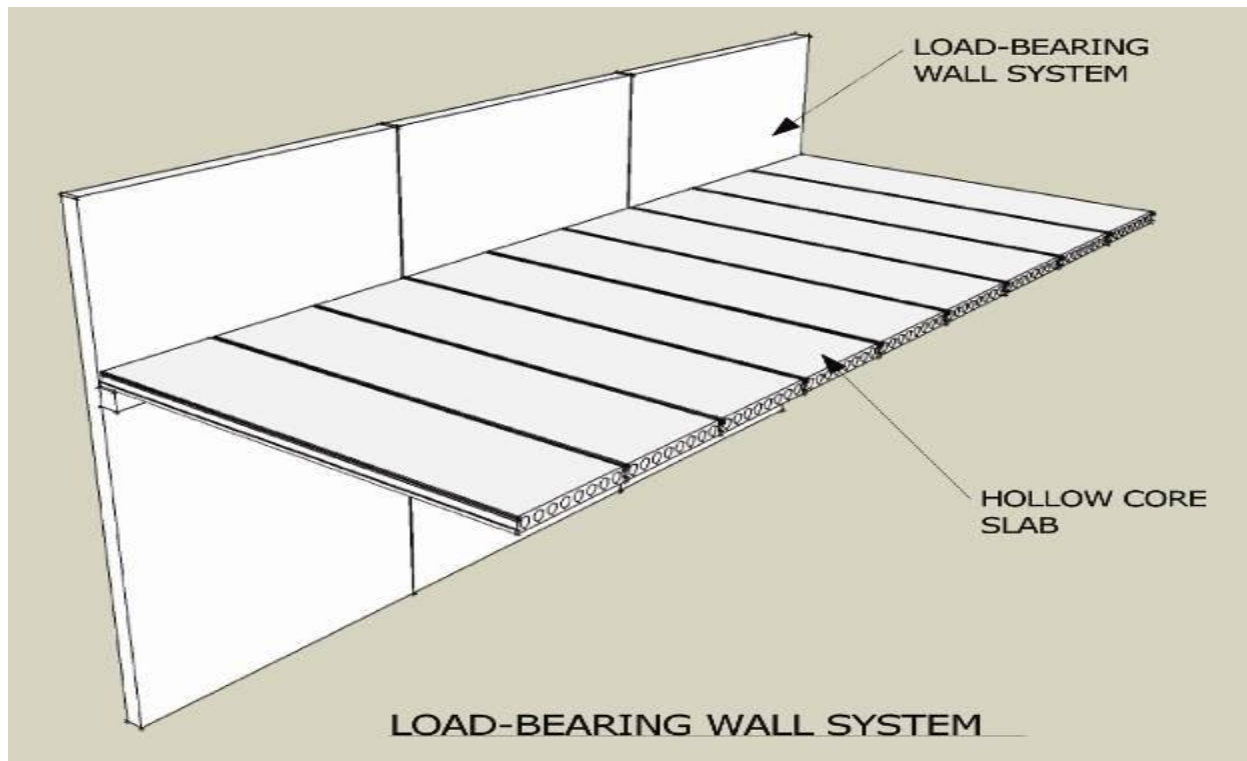

<http://www.we-inter.com/Conceptual-Design-for-a-Precast-Concrete-Hotel-in-Iraq.aspx>

Changing the lateral system from moment frames to reinforced load-bearing CMU's will result in simpler and easier frames to construct. Frame stiffnesses, and lateral movement; and both direct shear and torsional shear will be computed in the lateral system analysis to ensure the safety of the building.

This represents a viable option for a thesis project.

BREADTH TOPICS

CONSTRUCTION

Due to the redesign of the new lateral system; a cost and schedule impact will also be undertaken to determine the effects of the alterations. Including in this breadth will be estimates on the prices of new materials as well as installation costs and time. The overall cost of the new system will then be compared to the cost of the existing system. In addition, a schedule analysis will be done to determine a new critical path and whether the deadline of August 2010 would still be met. Cost and time changes will be included in the comparison of the two systems.

ARCHITECTURAL

By implementing a different floor system and continuous load bearing walls (option II) from the first floor to the roof, the existing floor plan of the DH will have to be redesigned. This presents an opportunity to also alter the existing layout of the rooms. Currently, the rooms are separated in the middle by a corridor that is approximately 300 feet long. However, changing the layout to an “atrium” like corridor or opening it up to commons areas would promote more student interaction, better ventilation, and an aesthetic environment. Therefore, an architecture breadth will be included to detail the impact of the CMU load-bearing walls on the overall building.

METHODS

Through consulting with faculty members and industry professionals as well as independent research, specific existing non load-bearing walls may be converted into reinforced CMU load-bearing walls. A new floor system consisting of precast hollow core planks will replace the existing floor joists. Then, changes in frame stiffnesses, lateral movement, and both direct and torsional shear will be analyzed and compared to industry standards as well as the current system. Spot checks will be undertaken to ensure that critical members have adequate capacity.

In addition, the effects of the alternate system on construction and architecture will be analyzed. After the walls are designed to industry standards; the amount of man hours needed for construction, the cost of materials and overall saving, will then be obtained using RSMeans 2010 Building construction Cost Data Book and other materials. A new critical path will be identified; and time and cost changes will be determined and compared to the existing system.

TASKS

Task 1

Determine load-bearing and non load-bearing CMU's based on faculty members and industry professionals' advice.

Task 2

Perform wind and seismic hand calculations and compare them to the existing system.

Task 3

Design a typical floor system and CMU load-bearing wall at different levels.

Task 4

Check direct shear and torsion.

Task 5

Check strength and serviceability against code and industry standards

Task 6

Architectural impact breadth: Change floor plans to accommodate new lateral system.

Task 7

Construction breadth: Schedule impact including new critical path; and cost and time changes.

Task 8

Write paper and make revisions as necessary.

Task 9

Prepare for final presentation.

TIMETABLE

Dauphin Hall - Penn College of Technology, Williamsport, PA

| Senior thesis Final 3/15/2012 | 1/27/2012 Milestone 1 | 2/13/2012 Milestone 2 | 3/2/2012 Milestone 3 | Spring Break | 3/26/2012 Milestone 4 | Aubert Ndjolba Structural Option Dr. Boothby | | | | | | | | | |
|---|--------------------------|--------------------------|-------------------------|--------------|--------------------------|--|-----------|----------|-----------|-----------|-----------|----------|----------|-----------|-----------|
| 9-Jan-12 | 16-Jan-12 | 23-Jan-12 | 30-Jan-12 | 6-Feb-12 | 13-Feb-12 | 20-Feb-12 | 27-Feb-12 | 5-Mar-12 | 12-Mar-12 | 19-Mar-12 | 26-Mar-12 | 2-Apr-12 | 9-Apr-12 | 16-Apr-12 | 23-Apr-12 |
| Proposed Thesis Semester Schedule January 2012-April 2012 | | | | | | | | | | | | | | | |
| <div style="display: flex; flex-direction: row-reverse;"> <div style="width: 100%; height: 100%; border: 1px solid black; padding: 5px;"> <p>Senior Banquet April 27th</p> </div> <div style="width: 100%; height: 100%; border: 1px solid black; padding: 5px;"> <p>Faculty Jury Presentations</p> </div> <div style="width: 100%; height: 100%; border: 1px solid black; padding: 5px;"> <p>Final Reports Due April 4th</p> </div> </div> | | | | | | | | | | | | | | | |
| <div style="display: flex; flex-direction: row-reverse;"> <div style="width: 100%; height: 100%; border: 1px solid black; padding: 5px;"> <p>ABET Evaluation & CPEP Update</p> </div> <div style="width: 100%; height: 100%; border: 1px solid black; padding: 5px;"> <p>Organize and format final report</p> </div> <div style="width: 100%; height: 100%; border: 1px solid black; padding: 5px;"> <p>Arrange final presentation</p> </div> </div> | | | | | | | | | | | | | | | |
| <div style="display: flex; flex-direction: row-reverse;"> <div style="width: 100%; height: 100%; border: 1px solid black; padding: 5px;"> <p>Check strength and serviceability</p> </div> <div style="width: 100%; height: 100%; border: 1px solid black; padding: 5px;"> <p>Check direct shear, torsion, and drift</p> </div> <div style="width: 100%; height: 100%; border: 1px solid black; padding: 5px;"> <p>Design floor system and load-bearing CMU walls</p> </div> <div style="width: 100%; height: 100%; border: 1px solid black; padding: 5px;"> <p>Perform wind and seismic hand calculations</p> </div> <div style="width: 100%; height: 100%; border: 1px solid black; padding: 5px;"> <p>Implement new lateral system</p> </div> <div style="width: 100%; height: 100%; border: 1px solid black; padding: 5px;"> <p>Revise Thesis proposal</p> </div> </div> | | | | | | | | | | | | | | | |
| <div style="display: flex; flex-direction: row-reverse;"> <div style="width: 100%; height: 100%; border: 1px solid black; padding: 5px;"> <p>Change floor plans to accommodate new sys. ** Implement facade changes</p> </div> <div style="width: 100%; height: 100%; border: 1px solid black; padding: 5px;"> <p>Create schedule and cost information</p> </div> </div> | | | | | | | | | | | | | | | |

| Milestones | |
|------------|--|
| 1 | Design of the alternative lateral system |
| 2 | Analysis of the alternative lateral system |
| 3 | Design of the new floor plans |
| 4 | Create a schedule and cost information and finalize the Final Report |

Note: ** Possible facade changes if necessary

| |
|--|
| Depth Topic: Alternative Lateral Systems |
| Breadth Topic 1: Cost/Schedule Analysis |
| Breadth Topic 2: Architecture: New floor plans |

CONCLUSION

An in-depth investigation will be undertaken to evaluate the impact of implementing reinforced CMU load-bearing wall in lieu of the existing moment frames. Once the best configuration and location of the walls have been selected, the alternate lateral system will be analyzed and compared to the existing. By altering the structural system, construction and architectural aspects of the DH will have to be studied and adjusted appropriately.